

# REARSENTRY™

ROSTRA OBSTACLE SENSING SYSTEM

## BASE KIT 250-1728



### CONTENTS

Parts List.....	2
Parts Diagrams .....	2
Before You Start .....	5
Installation.....	7
Troubleshooting Guide.....	11

# BASE KIT PARTS LIST

ITEM	QUANTITY	PART NUMBER	DESCRIPTION
1	1	250-2534	SENSOR/MODULE ASSEMBLY
2	1	250-2276	AUDIO CONTROL MODULE
3	1	250-2321	LED ASSEMBLY
4	1	250-4359	HARDWARE PACKAGE: CABLE TIES, SCREW, WASHER, NUT, SCOTCH LOCK, BOLTS.....
5	1	250-4339	8 FOOT POWER HARNESS
6	2	250-4353	SENSOR PROTECTIVE BRACKETS
7	3	250-4354	UNIVERSAL MOUNTING BRACKETS

**NOTE: THIS BASE KIT MUST BE USED IN CONJUNCTION WITH ONE OF THE VEHICLE-SPECIFIC FIT KITS DESCRIBED ON THE FOLLOWING PAGES.**

# BASE KIT PARTS DIAGRAM

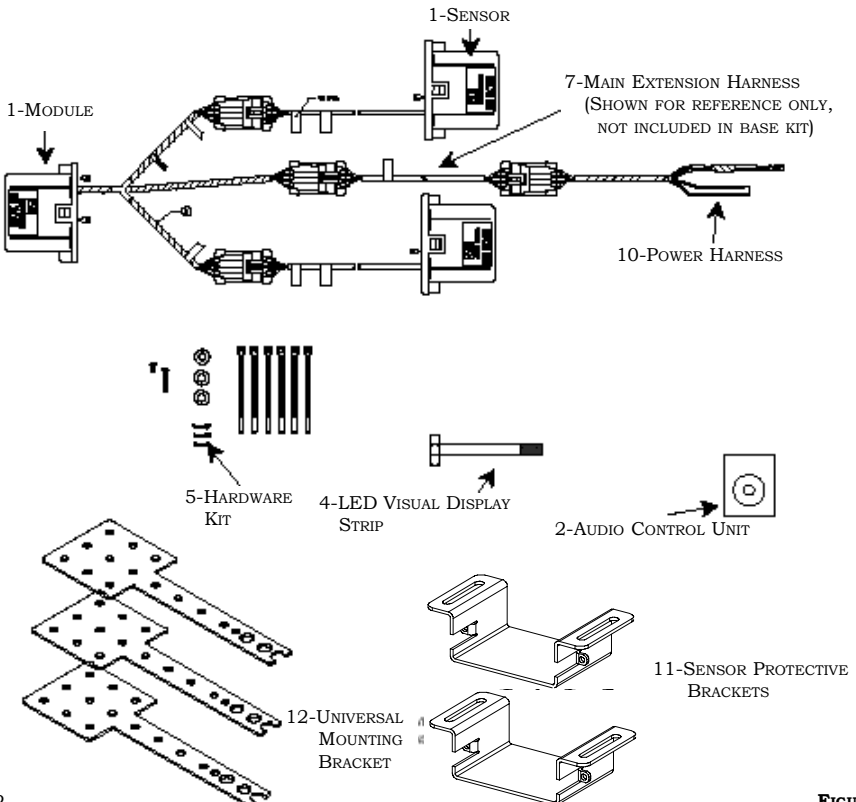

**250-2522 LIGHT DUTY  
FIT KIT PARTS LIST**

ITEM	QUANTITY	PART NUMBER	DESCRIPTION
8	1	250-4356	6" MAIN EXTENSION HARNESS
9	1	250-2277	LED EXTENSION HARNESS
10	1	250-4312	AUDIO CONTROL EXTENSION HARNESS

USE THIS KIT FOR THE FOLLOWING VEHICLES: MINI-VANS, FULL SIZE VANS,  
PICK-UP TRUCKS, SPORT UTILITIES

**250-2523 MEDIUM DUTY  
RAMP-STYLE FIT KIT PARTS LIST**

ITEM	QUANTITY	PART NUMBER	DESCRIPTION
8	1	250-4357	24' MAIN EXTENSION HARNESS
11	2	250-2521	3' SENSOR EXTENSION HARNESS
12	2	250-4355	PRE-BENT SENSOR MOUNTING BRACKETS

USE THIS KIT FOR THE FOLLOWING VEHICLES: BOX-STYLE DELIVERY VANS, SHORT CAB/TRAILER COMBOS, SHUTTLE BUSES, MEDIUM-SIZE SCHOOL BUSES

**250-2524 HEAVY DUTY RAMP-STYLE  
FIT KIT PARTS LIST**

ITEM	QUANTITY	PART NUMBER	DESCRIPTION
8	1	250-4358	32' MAIN EXTENSION HARNESS
11	2	250-2521	3' SENSOR EXTENSION HARNESS
12	2	250-4355	PRE-BENT SENSOR MOUNTING BRACKETS

USE THIS KIT FOR THE FOLLOWING VEHICLES: STRAIGHT-TRUCKS WITH RAMP-STYLE ACCESS OR NO AUTOMATIC LIFT

**250-2525 HEAVY DUTY  
LIFT-STYLE FIT KIT PARTS LIST**

ITEM	QUANTITY	PART NUMBER	DESCRIPTION
8	1	250-4358	32' MAIN EXTENSION HARNESS
11	1	250-4360	8' SENSOR EXTENSION HARNESS
12	2	250-4355	PRE-BENT SENSOR MOUNTING BRACKETS

USE THIS KIT FOR THE FOLLOWING VEHICLES: STRAIGHT-TRUCKS WITH HYDRAULIC LIFTS, DUMP TRUCKS, TOW TRUCKS

**250-2526 40 FOOT HEAVY DUTY  
RAMP-STYLE FIT KIT PARTS LIST**

<b>ITEM</b>	<b>QUANTITY</b>	<b>PART NUMBER</b>	<b>DESCRIPTION</b>
8	1	250-4338	40' MAIN EXTENSION HARNESS
11	2	250-2521	3' SENSOR EXTENSION HARNESS
12	2	250-4355	PRE-BENT SENSOR MOUNTING BRACKETS

USE THIS KIT FOR THE FOLLOWING VEHICLES: FULL-SIZE CITY TRANSIT OR SCHOOL BUSES

**250-2532 MEDIUM DUTY  
LIFT-STYLE FIT KIT PARTS LIST**

<b>ITEM</b>	<b>QUANTITY</b>	<b>PART NUMBER</b>	<b>DESCRIPTION</b>
8	1	250-4357	24' MAIN EXTENSION HARNESS
11	1	250-4360	8' SENSOR EXTENSION HARNESS
12	2	250-4355	PRE-BENT SENSOR MOUNTING BRACKETS

USE THIS KIT FOR THE FOLLOWING VEHICLES: BOX-STYLE DELIVERY VANS WITH HYDRAULIC LIFTS

**250-2533 40 FOOT HEAVY DUTY  
LIFT-STYLE FIT KIT PARTS LIST**

<b>ITEM</b>	<b>QUANTITY</b>	<b>PART NUMBER</b>	<b>DESCRIPTION</b>
8	1	250-4338	40' MAIN EXTENSION HARNESS
11	2	250-4360	8' SENSOR EXTENSION HARNESS
12	2	250-4355	PRE-BENT SENSOR MOUNTING BRACKETS

USE THIS KIT FOR THE FOLLOWING VEHICLES: EXTRA-LONG COMMERCIAL VEHICLES WITH HYDRAULIC LIFTS

## FIT KITS PARTS DIAGRAM

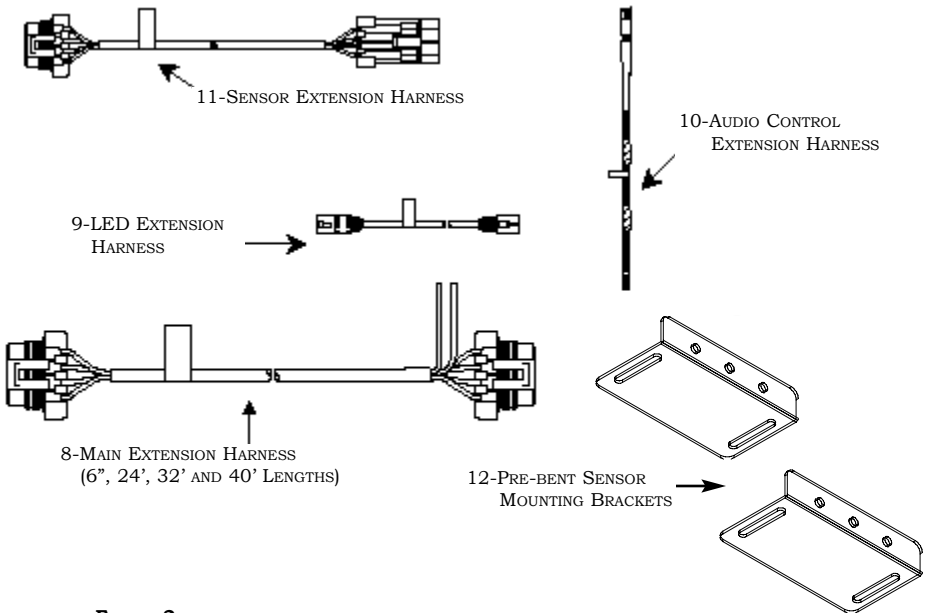

FIGURE 2

## BEFORE YOU START

**BEFORE BEGINNING INSTALLATION**, FAMILIARIZE YOURSELF WITH THE INSTALLATION INSTRUCTIONS AND THE RearSentry™ SYSTEM COMPONENTS.

TO ENSURE YOUR SAFETY:

- A) MAKE SURE YOUR VEHICLE IS IN "PARK".
- B) APPLY THE EMERGENCY BRAKE.
- C) PLACE WHEEL BLOCKS BEHIND THE REAR TIRES.
- D) IF YOU LIFT THE VEHICLE, ENSURE THAT YOU USE JACK STANDS AND FOLLOW THE VEHICLE'S MANUFACTURER LIFTING INSTRUCTIONS.
- E) READ THIS MANUAL BEFORE STARTING.

# INSTALLATION OVERVIEW

## KEY COMPONENTS:

ITEM	DESCRIPTION	FUNCTION
<b>A</b>	CONTROL MODULE	CONTROLS THE REARSENTRY™
<b>B</b>	MICROWAVE SENSORS	DETECTS OBSTACLES
<b>C</b>	AUDIO CONTROL UNIT (PIEZO)	AUDIBLY ALERTS THE DRIVER
<b>D</b>	LED DISPLAY	VISUALLY ALERTS THE DRIVER
<b>E</b>	MAIN EXTENSION HARNESS*	CARRIES SYSTEM SIGNALS
<b>F</b>	AUDIO/POWER HARNESS	CONNECTS TO REVERSE LIGHT CIRCUIT AND PIEZO UNIT
<b>G</b>	SENSOR EXTENSION HARNESS	INCREASES DISTANCE FROM MODULE TO SENSORS

\*AVAILABLE IN 6", 24', 32' AND 40' LENGTHS

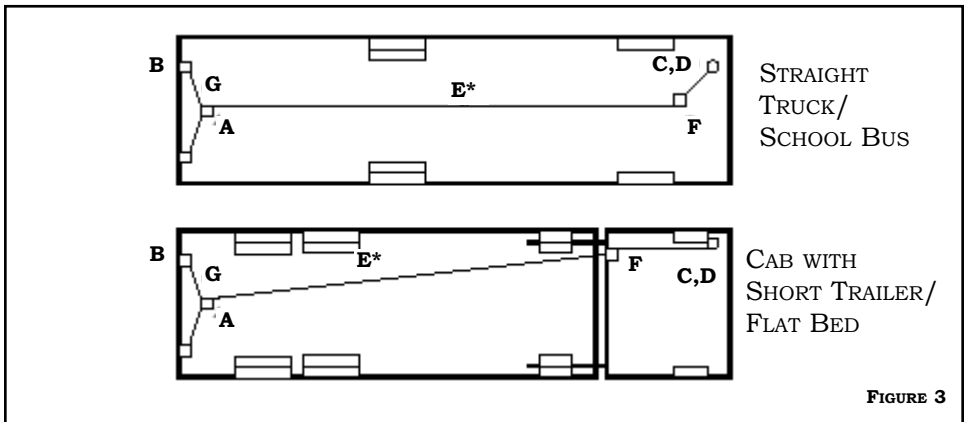

# INSTALLATION

**TO INSTALL THE REARSENTRY™, YOU WILL NEED TO DO THE FOLLOWING STEPS:**

## STEP 1: SENSOR LOCATION

1. THE OPTIMAL MOUNTING LOCATION FOR SENSORS IS TO PLACE THE SENSORS AT **1/3** INCREMENTS ALONG THE BUMPER AS SHOWN IN **FIGURE 4**. IF THE VEHICLE HAS NO BUMPER, FIND A SECURE PROTECTED AREA TO MOUNT THE SENSORS.
2. BEFORE INSTALLING THE REARSENTRY™, MAKE SURE THE SENSOR POSITION IS MORE THAN 14" ABOVE THE GROUND.
3. THE SENSORS SHOULD BE MOUNTED **PARALLEL** TO THE GROUND SURFACE AND FACING THE REAR OF THE VEHICLE.

**NOTE: FOR TRAILERS OR FLAT BEDS WITH VERY LOW BUMPERS, IT MAY BE BEST TO MOUNT THE SENSORS ON TOP OF THE BUMPER. THIS WAY THE SENSORS WON'T BE DAMAGED IF THE REAR END COMES CLOSE TO SCRAPING THE GROUND.**

4. MOUNT THE SENSORS AT LEAST 5" AWAY FROM THE TRAILER'S MOVING COMPONENTS. MOVING ITEMS MAY CAUSE FALSE ALARMS.
5. BE AWARE THAT IF THE SENSOR FACE IS TOO EXPOSED, DAMAGE TO THE SENSORS MAY OCCUR. MAKE SURE TO USE THE ENCLOSED SURROUND BRACKETS FOR PROTECTION.

## STEP 2: SENSOR MOUNTING

1. SENSORS MUST BE MOUNTED WITH THE DOUBLE-TABS UP. **FIGURE 5**
2. AT ALL TIMES, MAKE SURE THE SENSOR IS FIRMLY TIGHTENED AND CANNOT BE MOVED OR ROTATED. USE THE TWO BOLT ATTACHMENT METHOD (**FIGURE 6**) OR BRACKET ATTACHMENT METHOD (**FIGURE 7**) TO SECURE SENSORS TO THE BUMPER.

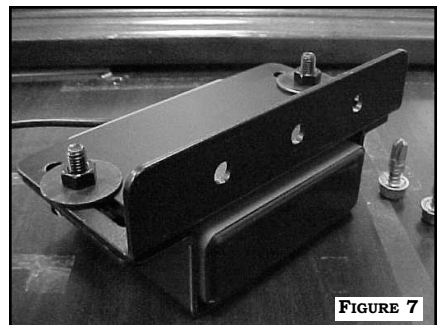
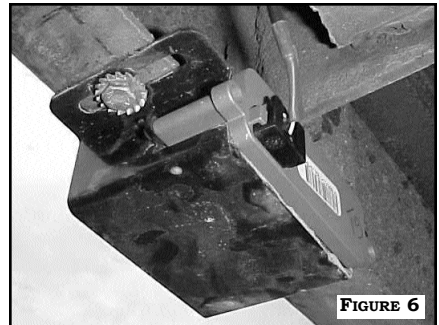
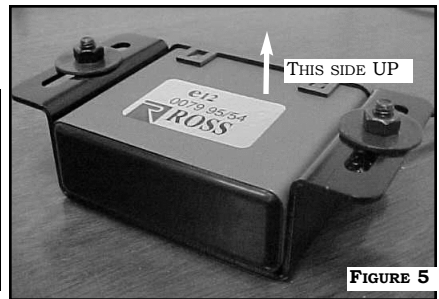
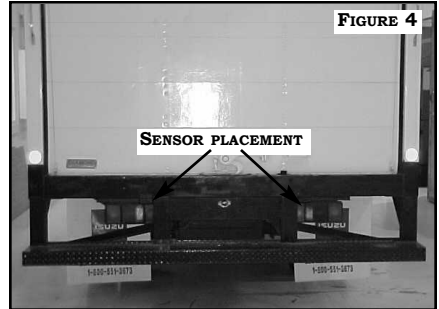

# INSTALLATION

## STEP 3: MODULE MOUNTING

**OBJECTIVE: MOUNT MODULE ASSEMBLY UNDER VEHICLE NEAR REAR BUMPER.**

### TASKS:

1. THE MODULE IS A WATERPROOF ASSEMBLY, SO IT COULD BE MOUNTED OUTSIDE THE VEHICLE NEAR AN EXISTING HOLE AT THE REAR OF THE VEHICLE.
2. LOCATE AN EXISTING HOLE BEHIND THE BUMPER AREA OR DRILL  $1/4"$  HOLE BEHIND THE BUMPER AND SECURE MODULE ASSEMBLY USING THE BOLT ATTACHMENT METHOD OR THE BRACKET ATTACHMENT METHOD TO INSTALL THE MODULE. **FIGURES 7 AND 8**
3. POSITION THE MODULE ASSEMBLY WITH THE BRACKET OR THE BOLT OVER AN EXISTING HOLE OR THE BUMPER METAL BEAM USING THE ENCLOSED SELF-TAPPING/DRILLING SCREWS SUPPLIED IN HARDWARE KIT.

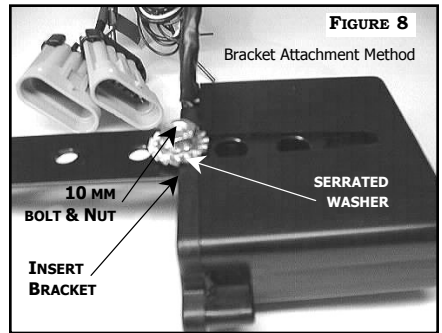
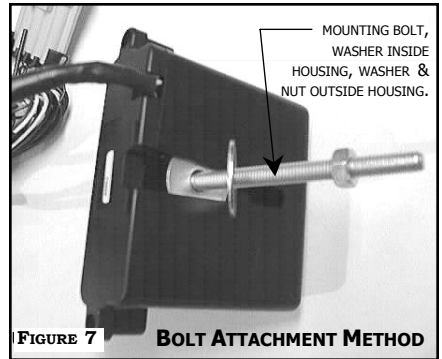

## STEP 4: WIRING HARNESS ROUTING

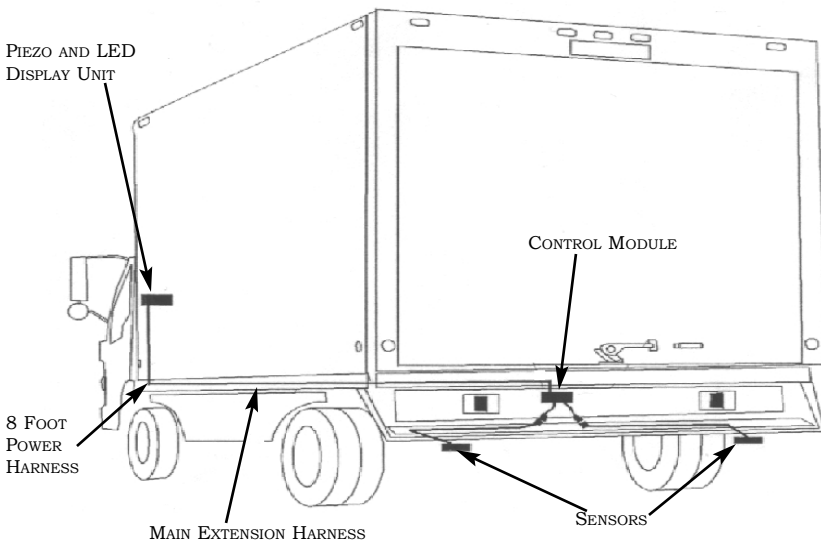

**FIGURE 9**



# INSTALLATION

## STEP 4: WIRING HARNESS ROUTING (CONTINUED)

**OBJECTIVE: CONNECT THE TWO OPEN WIRES FROM EITHER THE MAIN EXTENSION HARNESS OR THE POWER HARNESS (SEE FIGURE 1 ON PAGE 2 AND FIGURE 9 ON PAGE 8) TO THE VEHICLE'S REVERSE LIGHT WIRING.**

### TASKS:

1. CONNECT THE SENSORS TO THE CONTROL MODULE BY MATING THE BLACK 4-PIN MALE CONNECTORS TO THE GRAY FEMALE CONNECTORS FROM THE CONTROL MODULE. CONNECT RED TO RED AND GREEN TO GREEN.
2. CONNECT THE MAIN EXTENSION CABLE TO THE REMAINING GRAY CONTROL MODULE CONNECTOR AS SHOWN IN **FIGURE 1 ON PAGE 2**.
3. ROUTE THE 4-CONDUCTOR MAIN EXTENSION CABLE FROM THE CONTROL MODULE HARNESS ALONG THE FROG OF THE VEHICLE TO THE FRONT. SECURE THE HARNESSES WITH WIRE TIES. **FIGURE 9 ON PAGE 8**
4. USING A VOLTMETER, LOCATE THE +12 VOLT WIRE CONNECTED TO THE REVERSE LIGHTS WHEN THE VEHICLES REVERSE LIGHTS ARE ON. IF THE REVERSE LIGHT ASSEMBLY HAS 2 WIRES, LOCATE THE GROUND WIRE. IF THE REVERSE LIGHT ASSEMBLY DOES NOT HAVE 2 WIRES, LOCATE A GOOD CHASSIS GROUND.
5. ROUTE THE BLUE AND BLACK (POWER AND GROUND) PIGTAIL WIRES FROM THE MAIN EXTENSION HARNESS TO THE REVERSE LIGHT. **NOTE: YOU MAY ALSO ELECT TO MAKE POWER AND GROUND CONNECTIONS AT THE FRONT OF THE VEHICLE (TRANSMISSION SWITCH, FUSE BOX, ETC.) USING THE BLUE AND BLACK WIRES ON THE POWER HARNESS AS SHOWN IN FIGURE A. WHICHEVER SET YOU DO NOT USE, CUT THE WIRES OFF AND WRAP THE ENDS IN ELECTRICAL TAPE AS THEY WILL BE LIVE WIRES WHEN THE SYSTEM IS ACTIVATED.**
6. SOLDER (RECOMMENDED) OR SCOTCH LOCK THE **BLACK WIRE** TO GROUND.
7. SOLDER (RECOMMENDED) OR SCOTCH LOCK THE **BLUE WIRE** FROM THE WIRING HARNESS TO THE +12 VOLT WIRE AT THE REVERSE LIGHTS.
8. SECURE WITH CABLE TIES SUPPLIED IN THE INSTALLATION KIT.

**NOTE: KEEP MODULE HARNESS AWAY FROM SHARP, HOT OR MOVING OBJECTS**

## STEP 5: AUDIO CONTROL UNIT MOUNTING

**OBJECTIVE: TO MOUNT THE AUDIO CONTROL UNIT**

### TASKS:

1. FIND A SUITABLE LOCATION FOR THE AUDIO CONTROL UNIT ON THE INSIDE OF THE VEHICLE. IT MUST BE MOUNTED IN A LOCATION THAT WILL PERMIT THE DRIVER TO HEAR THE AUDIO ALERT. POTENTIAL MOUNTING SITES ARE BENEATH OR BEHIND THE DASH OR BEHIND THE A-PILLAR. **FIGURE 9 ON PAGE 8**
2. CONNECT THE 2-PIN CONNECTOR HARNESS (VIOLET AND WHITE) FROM THE POWER HARNESS TO THE AUDIO CONTROL UNIT. **FIGURE 10**

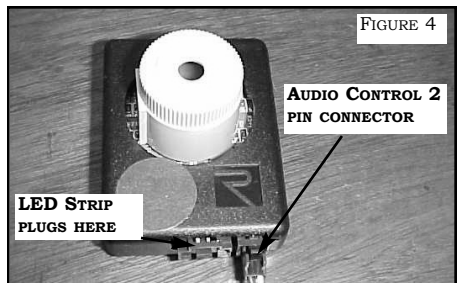

# INSTALLATION

## STEP 6: (LED) DISPLAY MOUNTING

**OBJECTIVE: MOUNT THE LED DISPLAY IN THE CAB OF THE VEHICLE WHERE THE DRIVER CAN EASILY VIEW IT WHEN OPERATING THE VEHICLE IN REVERSE.**

### TASKS:

1. CONNECT THE LEAD FROM THE LED UNIT TO THE AUDIO CONTROL UNIT MODULE. **FIGURE 10 ON PAGE 9**
2. SOME POSSIBLE LOCATIONS INCLUDE: THE WINDSHIELD, THE A PILLAR ON THE DRIVER'S SIDE OF THE WINDSHIELD, THE DASHBOARD.
3. PRIOR TO MOUNTING THE LED DISPLAY, CLEAN THE AREA FIRST WITH **ALCOHOL** THEN PEEL THE PROTECTIVE TAPE OFF OF THE ADHESIVE STRIP ON THE BACK OF THE LED DISPLAY; PLACE LED DISPLAY.
4. IF THE WIRE CONNECTING THE AUDIO AND LED UNITS IS TOO SHORT, USE THE OPTIONAL LED EXTENSION HARNESS.

**WHEN INSTALLING THE LED, CLEAN THE LOCATION AREA WITH ALCOHOL. MAKE SURE THE LED IS PLACED IN THE CORRECT LOCATION. TRYING TO REMOVE LED CAN CAUSE DAMAGE TO THE LED DISPLAY**

## STEP 7: TESTING PROCEDURE

**OBJECTIVE: TEST TO ENSURE THAT THE REARSENTRY™ IS OPERATING PROPERLY. IF, AT ANY POINT, THE REARSENTRY™ DOES NOT OPERATE PROPERLY, REFER TO THE TROUBLESHOOTING GUIDE IN THE OWNER'S MANUAL.**

**THE MANUFACTURER IS NOT RESPONSIBLE FOR ANY RADIO OR TV INTERFERENCE CAUSED BY UNAUTHORIZED MODIFICATIONS TO THIS EQUIPMENT. SUCH MODIFICATIONS COULD VOID THE USER'S AUTHORITY TO OPERATE THE EQUIPMENT**

**ROSS DEVICE COMPLIES WITH PART 15 OF THE FCC RULES. OPERATION IS SUBJECT TO THE FOLLOWING TWO CONDITIONS: (1) THIS DEVICE MAY NOT CAUSE HARMFUL INTERFERENCE, AND (2) THIS DEVICE MUST ACCEPT ANY INTERFERENCE RECEIVED, INCLUDING INTERFERENCE THAT MAY CAUSE UNDESIRABLE OPERATION.**

# ROSS TROUBLESHOOTING

<b>AUDIBLE TONE</b>	<b>VISUAL RESPONSE</b>	<b>EVENT</b>
NONE	SOLID GREEN LED	SENSOR ACTIVATED
NONE	FLASHING GREEN	SENSOR INITIALLY DETECTS MOVEMENT
SLOW BEEPING	FLASHING AMBER	FIRST DETECTABLE ZONE
FAST BEEPING	FLASHING RED	SECOND DETECTABLE ZONE
CONTINUOUS	SOLID RED	FINAL DETECTABLE ZONE

## **PROBLEM**

No LED DISPLAY, OUTPUT ONLY

No AUDIO OUTPUT, LED DISPLAY ONLY

No LED DISPLAY OR AUDIO OUTPUT

## **CHECK THE FOLLOWING**

1. REPLACE LED STRIP

1. REPLACE AUDIO CONTROL UNIT

1. MAKE SURE AUDIO CONTROL HARNESS IS CONNECTED.
2. USE A VOLTMETER TO TEST FOR AT LEAST +3 VOLTS AT THE TERMINAL OF THE AUDIO CONTROL HARNESS (WHITE & PURPLE WIRES)
3. VERIFY SYSTEM POWER AND GROUND CONNECTIONS
  - USE A VOLTMETER TO TEST FOR AT LEAST +9 VOLTS AT THE POWER CONNECTION (BLUE WIRE)
  - USE AN OHM METER TO TEST FOR NO MORE THAN 3 OHMS AT THE GROUND CONNECTION (BLACK WIRE)
4. INSPECT ALL HARNESSES FOR PINCH THAT MIGHT CAUSE A SHORT CIRCUIT.
5. REPLACE THE CONTROLLER MODULE.

# ROSS TROUBLESHOOTING

## PROBLEM

## CHECK THE FOLLOWING

LED SHOWS SOLID GREEN AT ALL TIMES

1. POWER THE SYSTEM AND WALK IN FRONT OF THE SENSORS TO VERIFY THEIR OPERATION.
2. IF BOTH SENSORS WORK PROPERLY, VERIFY THAT THE INSTALLATION IS CORRECT. IF ANY SENSOR IS NOT WORKING, GO TO STEP 3.
3. REMOVE THE SENSOR(S). POWER THE SYSTEM AND WAVE YOUR HAND IN FRONT OF THE SENSOR.
  - IF SENSORS WORK PROPERLY, CHECK THE INSTALLATION.
  - IF ONLY ONE SENSOR WORKS, REPLACE BAD SENSOR.
  - IF NEITHER SENSOR WORKS, REPLACE CONTROLLER.

SYSTEM NOT SENSITIVE ENOUGH-NO FLASHING AMBER OR RED, ONLY FLASHING GREEN

1. TEST THE SYSTEM AS DESCRIBED IN THE TESTING SECTION. IF THE SENSITIVITY IS TOO LOW:
  - FOR BEHIND-THE-BUMPER APPLICATIONS, MOVE SENSORS PAST FOAM CLOSER TO PLASTIC FASCIA.
  - FOR BELOW-THE-BUMPER APPLICATIONS, MOVE THE SENSORS FORWARD (TOWARDS THE REAR OF CAR)
2. REPEAT STEP 1.

SYSTEM TOO SENSITIVE-SHOWS FLASHING OR SOLID RED TOO SOON, OR NO OBSTACLE

1. POWER THE SYSTEM WITH ENGINE OFF.
  - IF THE SYSTEM GOES SOLID RED IMMEDIATELY, REPLACE THE CONTROLLER MODULE.
  - IF SYSTEM SHOWS SOLID GREEN, GO TO STEP 2.
2. POWER THE SYSTEM WITH THE ENGINE RUNNING.
  - IF THE SYSTEM GOES FLASHING RED IMMEDIATELY, CHECK TO MAKE SURE THAT THE BRACKETS ARE TIGHT AND THAT THE SENSORS ARE NOT SURROUNDED BY METAL. VIBRATIONS MAY CAUSE THE SYSTEM TO FALSE TRIGGER.
  - IF SYSTEM SHOWS SOLID GREEN, GO TO STEP 3.
3. POWER THE SYSTEM WITH THE CAR MOVING IN REVERSE.
  - IF THE SYSTEM SHOWS FLASHING AMBER OR RED WITH OBSTACLES PRESENT, ANGLE THE SENSOR BRACKETS UP TO (10) DEGREES UPWARD.
  - DECREASE THE AIR GAP AROUND THE SENSORS. MAKE SURE THEY ARE FLUSH AGAINST THE FASCIA WHEN MOUNTED BEHIND THE BUMPER.